

Installation and Maintenance

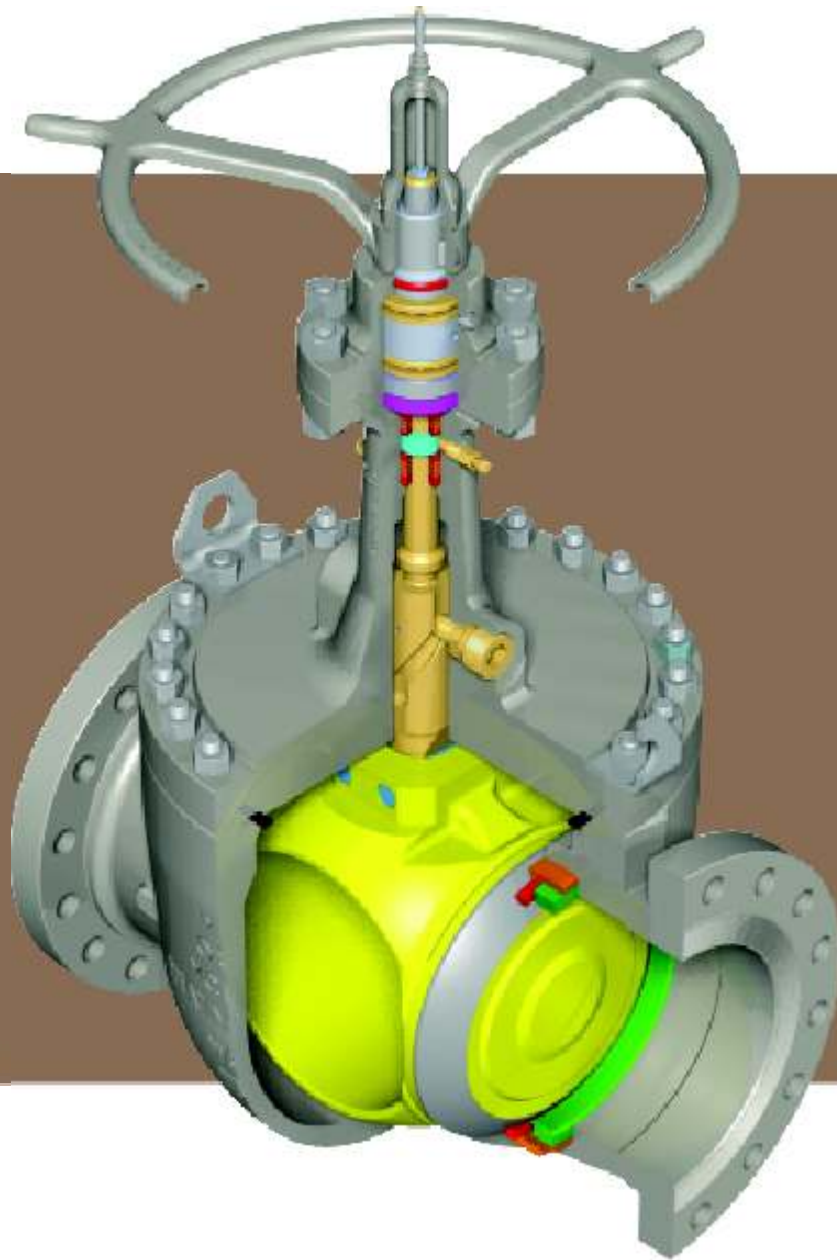

ORBIT[®]

INSTALLATION AND MAINTENANCE INTRODUCTION

To achieve maximum performance and to prolong equipment life, it is important to have correct installation and proper maintenance.

Orbit Valves and Actuators are designed to require a minimum amount of maintenance.

Lubrication isn't necessary to effect a seal, only to reduce friction and wear on moving parts.

An effective lubrication program should be established from experience with the valve for its particular application and frequency of operation.

Orbit's recommended lubrication schedule should be used as a minimum guideline.

All Orbit Valves are equipped with an adjustable stem packing chamber which is required only if a stem leak should develop.

BEFORE YOU BEGIN

This manual outlines the correct methods for proper installation and maintenance of Orbit Valves and Actuators.

It is laid out in step by step procedures and should be followed closely to prevent damage to the valves (and/or actuators) or injury to personnel.

WARNING

Valves are pressure containing vessels which can be dangerous if not handled correctly.

DO NOT REMOVE ANYTHING ON THE VALVE OR ACTUATOR UNLESS SPECIFICALLY INSTRUCTED TO DO SO IN THIS MANUAL, OR WITHOUT FIRST CONSULTING AN ORBIT REPRESENTATIVE.

FAILURE TO DO SO COULD RESULT IN INJURY TO PERSONNEL AND DAMAGE TO VALVE, ACTUATOR AND PROPERTY.

OTHER LITERATURE AVAILABLE

This manual covers only installation and maintenance of Orbit Valves and Actuators. Other information includes:

VALVE REPAIR

ACTUATOR REPAIR

ACTUATOR SIZING GUIDE

PRODUCT INFORMATION

TECHNICAL CATALOG

Consult your Orbit Representative for additional information on Orbit Valves and Actuators.

TABLE OF CONTENTS

INSTALLATION AND MAINTENANCE

Pre-Installation Inspection _____	2
Installation of Manually Operated Valves _____	3 & 4
Installation of Actuated Valves _____	5, 6 & 7

REFERENCE DATA

Figure Number Codes _____	8
Position Indicator Reference Chart _____	8
End Flange Bolting Dimensions _____	9 & 10
Groove Numbers for Ring Type Joint (RG/RTJ) Flanges _____	10
Valve Illustrations Showing Lube Points _____	11

LUBRICATION

Lubrication Schedule and Recommended Lubricants _____	12
Valve and Actuator Lubrication _____	12, 13 & 14

STEM PACKING ADJUSTMENT

Stem Packing Adjustment _____	15 & 16
Stem Packing Materials _____	17

DRILLING VALVES

Installation, Lubrication and Stem Packing Adjustment _____	17
---	----

TRADEMARK INFORMATION _____	18
-----------------------------	----

TERMS AND CONDITIONS _____	19
----------------------------	----

ADDITIONAL ORBIT INFORMATION

The Company and its Products

Technical Reference Data

Dimensional Data, Valves and Actuators

Automated Valve Packages

Standard Instrumentation Packages

Parts List and Ordering Instructions

INSTALLATION AND MAINTENANCE PRE-INSTALLATION INSPECTION

1 The first step is to check the valve nameplate for size, class and trim. Size and class are also marked on the body.



5 On handwheel valves, cycle fully open and fully closed to check for ease of operation. Check indicator rod travel against dimensions on page 8 to verify full stem travel.



2 Verify that the valve is suitable for the service in which it is being installed by referring to the service tag and nameplate.

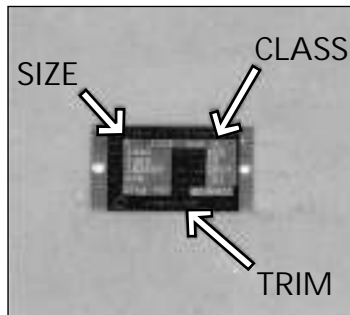

6 For valves equipped with power actuators, verify that a proper air supply or electric power source is available.



3 Check the handwheel and position indicator rod for possible damage.



7 For actuated valves equipped with an instrument package, verify that all components and piping are undamaged.



4 On flanged valves, remove the flange protectors and inspect the flange facings for deep nicks and scratches.

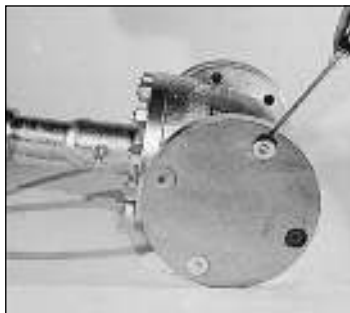

8 After these points have been checked and approved, the valve is ready for installation.



INSTALLATION AND MAINTENANCE

INSTALLATION OF MANUALLY OPERATED VALVES

1 Small valves (as shown at right) may be lifted or carried by the handwheel without damage to the valve.



5 This will provide longer valve life and easier operation.



2 Larger valves should be lifted by using the lifting lugs provided, or by looping a chain around bonnet as shown at right.



6 The words preferred pressure end have been abbreviated to "Pref. Pres. End" and can be found stamped on one end connection. This stamping is marked with red paint.



3 Never lift larger valves by the handwheel. Attempts to lift a large or heavy valve in this fashion can result in injury to personnel and damage to valve and property.



7 When possible, Orbit valves should be installed with the bonnet in a vertical position. When repairs are necessary, consult your Orbit representative for details on how to repair an Orbit valve without removing it from the line.

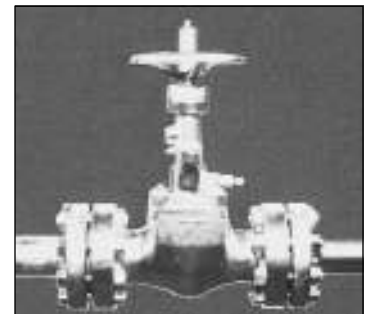

4 During installation, orient the valve so that the preferred pressure end will be toward the higher pressure, when the valve is closed.

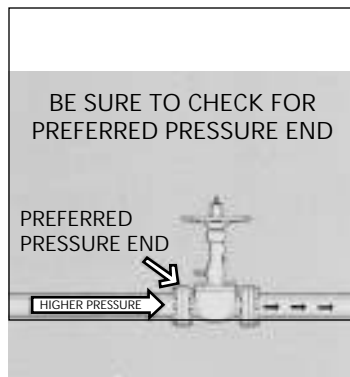

8 Orbit flanged valves can be bolted into the line using standard studs and nuts. See pages 9 and 10 for more information.

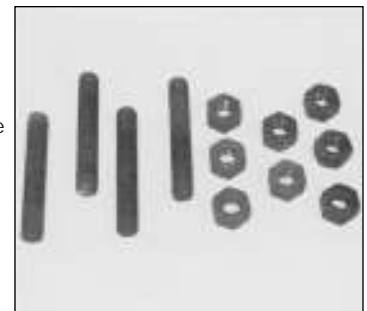

INSTALLATION AND MAINTENANCE

INSTALLATION OF MANUALLY OPERATED VALVES (CONTINUED FROM PREVIOUS PAGE)

9 Orbit block and bleed, or grease seal valves are threaded for a fitting, but are shipped with a pipe plug to prevent damage to the valve and/or fitting. The pipe plug should now be removed and replaced with the proper fitting.



13 Securely tighten with a pipe wrench. For safety, threaded piping requires secure anchoring of all components that are screwed into threaded valves.



10 On threaded valves, inspect the threads in both ends of the valve to verify no damage occurred during shipment. Be sure there is no dirt, grit, or chips in the valve bore or threads.



14 For weld end valves the temperature required to weld the valve into the line will exceed the rated working temperature of the valve. Orbit valves with Nylon or Teflon seats are vulnerable to damage by excessive heat, so use the following precautions.



15 Close the valve before welding to protect the seat and core face.



11 Apply a quality thread compound to the threads on the pipe.



16 We recommend the size of the weld rod never exceeds 5/32 in. (4.0 mm) diameter and the maximum body temperature does not exceed the valve rating during welding.

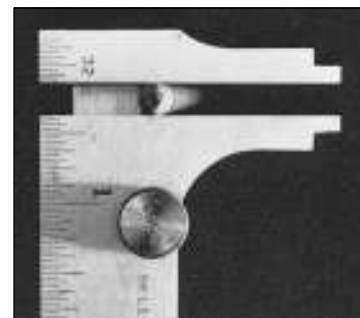

12 Carefully align the pipe and valve threads and thread the valve clockwise on the pipe.



17 When insulating low temperature valves, do not insulate above this line. Insulating above this line can result in injury to personnel and damage to valve and property.



INSTALLATION AND MAINTENANCE INSTALLATION OF ACTUATED VALVES

1 Orbit automated packages are equipped with lifting eyes. These should be used during installation to prevent damage to the unit and avoid injury to personnel.



5 The words preferred pressure end have been abbreviated to "Pref. Pres. End" and are stamped on one end connection. It is marked with red paint for easy identification.



2 For valves equipped with actuators not manufactured by Orbit, use lifting eyes if present. Otherwise, loop a chain around the valve bonnet to lift the unit.



6 On piston actuated valves, a gas over oil tank is provided to assure smooth operation and prevent valve damage.



3 During installation orient the valve so that the preferred pressure end will be toward the higher pressure when the valve is closed.

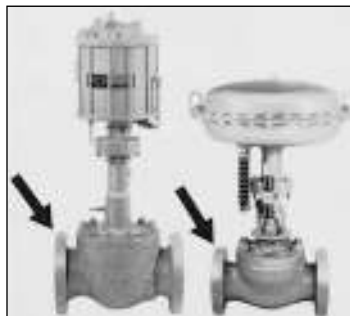

7 The gas over oil tank must be in the vertical position when the valve is installed. Unless otherwise specified at the time of order, the gas over oil tank will be mounted in this position.

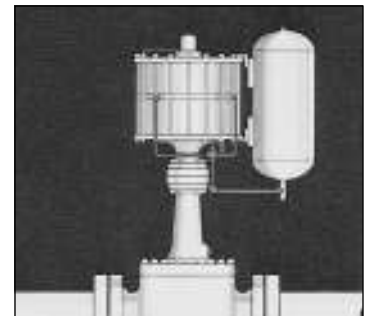

4 This is important because it reduces wear and because the valve may be rated at a different working pressure when installed in the opposite direction.



8 If your valve and actuator package is to be installed with the stem in other positions, the gas over oil tank must be mounted vertically. For example, in a horizontal piping run. Depending on valve and actuator combination, bracing may be required to support actuator.

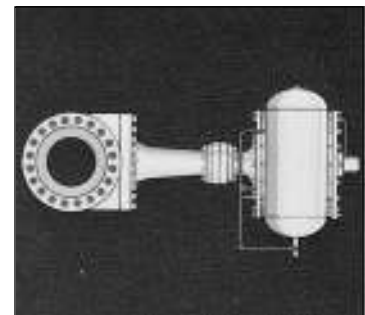

(CONTINUED ON NEXT PAGE)

INSTALLATION AND MAINTENANCE

INSTALLATION OF ACTUATED VALVES (CONTINUED FROM PREVIOUS PAGE)

9 Or in a vertical run. Depending on the valve and actuator combination, bracing may be needed to support the actuator.

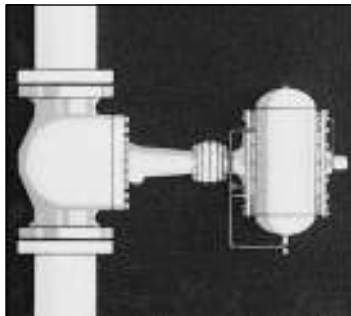

13 Unless otherwise specified on the nameplate, the minimum actuator pressure should always be within 5 psi, 0.3 bar of maximum pressure.



10 Orbit valves and actuators can be installed in the line using standard studs, nuts and gaskets. See pages 9 and 10 for more information.

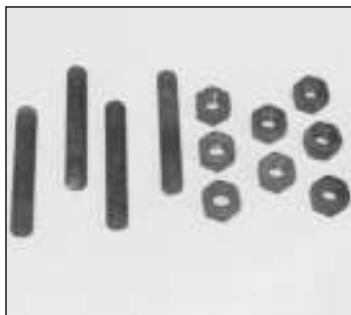

14 Connect the opening air supply for the diaphragm actuator to the bottom point A. Connect the closing air supply to the top point B.

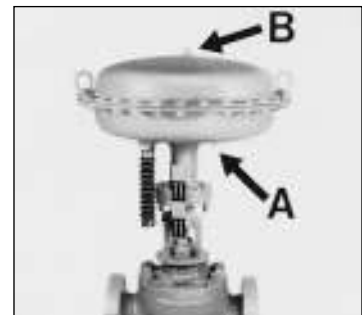

11 After the valve and actuator unit has been installed in the line, the actuator power supply should be connected.

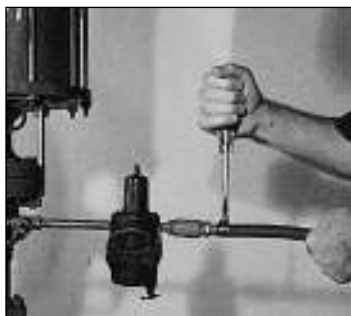

15 The first step in installing an Orbit Piston Actuated Valve is to check the NAMEPLATE to determine if the actuator is the LG type or the LS type. LG or LS will be the first letters of the actuator figure number. For example, LS-124-D-3-X-S.



12 IMPORTANT! For pneumatic actuators manufactured by Orbit, the supply pressure must be regulated to the amount shown on the nameplate. Failure to comply with this can damage the unit.



16 If the nameplate is illegible do not attempt to install without consulting an Orbit Representative.



INSTALLATION AND MAINTENANCE

INSTALLATION OF ACTUATED VALVES (CONTINUED FROM PREVIOUS PAGE)

17 On LG type double acting piston actuators, the closing air supply is connected to point A and the opening air supply is connected to the top of the gas over oil tank point B.

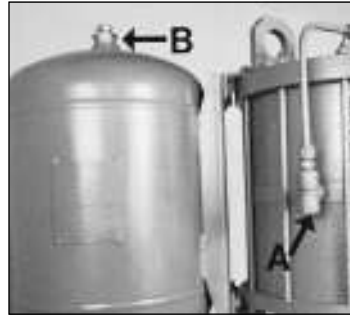

21 Also on LS spring close piston actuators the pipe plug on top of the gas over oil tank must be replaced with the filter breather supplied. Failure to do this could keep the unit from operating and result in injury to personnel and damage to valve, actuator and property.



18 For LG type spring close piston actuators the opening air supply is connected to the top of the gas over oil tank point B. On loss of air supply, the actuator closes forcing the oil into the tank.

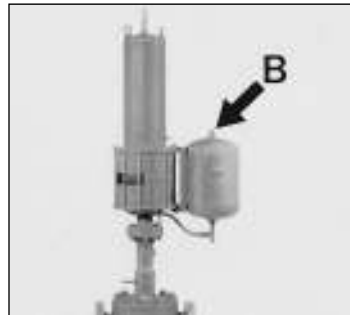

22 Most piston actuators except those equipped with a hydraulic open mechanism will be the LS model. The Double Acting piston with a hydraulic open model will continue to be the LG type.



19 The LS type piston actuator is a new design that reduces the size of the gas over oil tank and allows quicker operating times. The opening air supply is connected at point A and the closing air supply is connected to the top of the gas over oil tank point B.

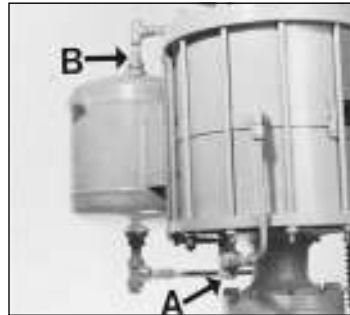

23 Cycle the valve fully open and fully closed to verify correct operation. Check the indicator rod for full travel. Rod travel distance can be found on page 8. Check the instrumentation for correct operation.







20 For LS type spring close piston actuator the opening air supply is at point A. Failure to connect the opening air supply to this point will keep the actuator from opening the valve.



24 The valve and actuator package is now ready for operation.



INSTALLATION AND MAINTENANCE - ORBIT FIGURE NUMBER CODES

ORBIT VALVE			STANDARD TRIM	
LITTLE ROCK, ARK				
SIZE	3" 900 CL		END TO END 15"	
FIG	1523H RF		1995 MOP AT +500F	
	SN 110091620001		2250 MOP AT -20F 	
PKG	GP6		STEM AS	
SEAT	CR13 TEF		BODY STEEL WCC	
MFG	6D-0073		CORE TRIM 17-4	
DATE	04/01 ISO 14313		CORE FACE NI	
IMPACTTEMP	-50F		TEMP -20/+500F	

MODEL

1. Carbon Steel Valves (API 6D or ASME B16.34)
2. Carbon Steel and Low Alloy
3. Low Alloy Steel Valves (WC6, WC9, C5)
4. API Wellhead Valves
5. British Gas Council
6. Corrosive 316 SS (-100°F)
7. Duplex Stainless Steel
8. Drilling Valves
9. High Alloy (Monel, Hastelloy, Inconel, 6MO)

CLASS PN

- | | |
|--------------|-----|
| 1. ASME 150 | 20 |
| 2. ASME 300 | 50 |
| 4. ASME 600 | 64 |
| 5. ASME 900 | 100 |
| 6. ASME 1500 | 250 |
| 7. ASME 2500 | 420 |
| 3. API 1000 | - |
| 5. API 2000 | - |
| 6. API 3000 | - |
| 7. API 5000 | - |

PORT SIZE & CONNECTION

2. Full Port, Flanged and Hub End
3. Reduced Port, Flanged and Hub End
4. Full Port, Threaded
5. Reduced Port, Butt Weld and Socket Weld
6. Full Port, Butt Weld
6. Full Port, Socket Weld
6. Full Port, Butt Weld x RF
7. Full Port, Special
8. Reduced Port, Special

TRIM*

0. T3 Modified
2. T7 Modified
3. Standard (T3)
5. Special Preparation
7. Sour Corrosive (T7)
8. Low Temp./Corrosive (316 SS) (T8)

SUFFIX**

- A, H, H8 - Type of Seat
 L - Adapted for Actuator
 BB - Block and Bleed Model
 GS - Grease Seal Model
 S - Non-Standard End to End Dimension

* For a more complete explanation of trims and figure numbers, consult you Orbit Representative.

** Valve figure numbers may use more than one suffix. Example: 1423H8L.

POSITION INDICATOR REFERENCE CHART

On an Orbit Actuator or an Orbit Valve with a rising stem valve position indicator, the indicator rod shows valve position. To determine if a valve, or valve and actuator package is achieving full travel, measure the protruding portion of the indicator rod in the closed position. Cycle the valve and measure the indicator rod in the open position. Subtract to find valve travel.

VALVE SIZE		ASME CLASS	NOMINAL TRAVEL	
in.	mm		in.	mm
1	25	150-2500	1 1/8	29
1 1/2	40	150-600	1 1/2	38
1 1/2	40	900-1500	1 3/4	44
2 x 1 1/2 x 2	50 x 40 x 50	150-600	1 1/2	38
2, 3 x 2 x 3	50, 80 x 50 x 80	150-600	1 1/2	38
2, 3 x 2 x 3	50, 80 x 50 x 80	900-1500	1 3/4	44
2, 3 x 1 13/16 x 3	50, 80 x 46 x 80	2500	1 3/4	44
3, 4 x 3 x 4	80, 100 x 80 x 100	150-300	1 1/2	38
3, 4 x 3 x 4	80, 100 x 80 x 100	600	1 3/4	44
3, 4 x 3 x 4	80, 100 x 80 x 100	900-1500	2 1/4	57
3, 4 x 3 x 4	80, 100 x 80 x 100	2500	2 1/4	57
4, 6 x 4 x 6	100, 150 x 100 x 150	150-300	1 3/4	44
4, 6 x 4 x 6	100, 150 x 100 x 150	600-900	2 1/4	57
4, 6 x 4 x 6	100, 150 x 100 x 150	1500	2 15/32	63
4, 6 x 4 x 6	100, 150 x 100 x 150	2500	2 3/8	60
6, 8 x 6 x 8	150, 200 x 150 x 200	150-300	2 15/32	63
6, 8 x 6 x 8	150, 200 x 150 x 200	600	2 7/8	73
6, 8 x 6 x 8	150, 200 x 150 x 200	900	3 1/4	83
6, 8 x 6 x 8	150, 200 x 150 x 200	1500	3 5/8	92
6, 8 x 6 x 8	150, 200 x 150 x 200	2500	3 3/4	95
8, 10 x 8 x 10	200, 250 x 200 x 250	150-300	2 7/8	73
8, 10 x 8 x 10	200, 250 x 200 x 250	600	3 1/4	83
8, 10 x 8 x 10	200, 250 x 200 x 250	900	4 1/4	108
8, 10 x 8 x 10	200, 250 x 200 x 250	1500	7 1/2	191
8, 10 x 8 x 10	200, 250 x 200 x 250	2500	8 15/16	227
10, 12 x 10 x 12	250, 300 x 250 x 300	150-300	3 1/4	83
10, 12 x 10 x 12	250, 300 x 250 x 300	600	4 1/4	108
10, 12 x 10 x 12	250, 300 x 250 x 300	900	4 3/8	111
10, 12 x 10 x 12	250, 300 x 250 x 300	1500	8 15/16	227
12, 14 x 12 x 14	300, 350 x 300 x 350	150-300	4 1/4	108
12, 14 x 12 x 14	300, 350 x 300 x 350	600	4 11/16	119
12, 14 x 12 x 14	300, 350 x 300 x 350	900	5 3/8	137
12, 14 x 12 x 14	300, 350 x 300 x 350	1500	10 7/8	276
14	350	300	4 1/4	108
16	400	900	10 7/8	276
16, 18 x 16 x 18	400, 450 x 400 x 450	150-600	5 9/16	141
16, 20 x 16 x 20	400, 500 x 400 x 500	150-600	5 9/16	141
18	450	150	5 7/8	150
20, 24 x 20 x 24	500, 600 x 500 x 600	300-900	10 7/8	275

INSTALLATION AND MAINTENANCE END FLANGE BOLTING DIMENSIONS

ASME/ANSI	CLASS 150				CLASS 300				CLASS 600				
Valve Size in.	Number of Fasteners Per Valve	Fastener Diameter in.	Length of Studs in.	*Length of Capscrews in.	Number of Fasteners Per Valve	Fastener Diameter in.	Length of Studs in.	*Length of Capscrews in.	Number of Fasteners Per Valve	Fastener Diameter in.	Length of Stud in. RF in.	Length of Stud in. RTJ in.	*Length of Capscrew in.
1	8	1/2	3	-	8	5/8	3 1/4	-	8	5/8	3 1/2	3 1/2	-
1 1/2	8	1/2	3 1/4	-	8	3/4	3 1/2	-	8	3/4	4 1/4	4 1/4	-
2 x 1 1/2 x 2	8	5/8	3 1/4	-	16	5/8	3 1/2	-	16	5/8	4 1/4	4 1/4	-
2	8	5/8	2 1/2	-	8	5/8	3 1/2	-	16	5/8	4 1/4	4 1/4	-
2 BB/GS*	8	5/8	3 1/2	1 1/2	-	-	-	-	-	-	-	-	-
3 x 2 x 3	8	5/8	2 1/2	-	16	3/4	4 1/4	-	16	3/4	5	5	-
3*	8	5/8	2 1/2	1 1/2	16	3/4	4 1/4	-	16	3/4	5	5	-
4 x 3 x 4*	16	5/8	2 3/4	1 3/4	16	3/4	4 1/2	-	16	7/8	5 3/4	5 3/4	-
4*	16	5/8	2 3/4	1 3/4	12	3/4	4 1/2	-	16	7/8	5 3/4	5 3/4	-
	-	-	-	-	4	3/4	-	2 1/4	-	-	-	-	-
6 x 4 x 6	16	3/4	4	-	24	3/4	4 3/4	-	24	1	6 3/4	6 3/4	-
6*	16	3/4	3	2	16	3/4	4 3/4	-	24	1	6 3/4	6 3/4	-
	-	-	-	-	8	3/4	-	2 1/2	-	-	-	-	-
8 x 6 x 8	16	3/4	4 1/4	-	24	7/8	5 1/2	-	24	1 1/8	7 1/2	7 3/4	-
8*	12	3/4	4 1/4	1 1/2	16	7/8	5 1/2	-	24	1 1/8	7 1/2	7 3/4	-
	4	3/4	-	2	8	7/8	-	3	-	-	-	-	-
10 x 8 x 10*	20	7/8	4 1/2	-	28	1	6 1/4	-	32	1 1/4	8 1/2	8 1/2	-
	4	7/8	4 1/2	2 1/4	4	1	-	3 3/4	-	-	-	-	-
10	24	7/8	4 1/2	-	32	1	6 1/4	-	32	1 1/4	8 1/2	8 1/2	-
12 x 10 x 12	24	7/8	4 3/4	-	32	1 1/8	6 3/4	-	40	1 1/4	8 3/4	8 3/4	-
12	24	7/8	4 3/4	-	32	1 1/8	6 3/4	-	40	1 1/4	8 3/4	8 3/4	-
14 x 12 x 14	24	1	5 1/4	-	40	1 1/8	7	-	40	1 3/8	9 1/4	9 1/4	-
14	-	-	-	-	40	1 1/8	7	-	40	1 3/8	9 1/4	9 1/4	-
16 x 12 x 16	-	-	-	-	-	-	-	-	40	1 1/2	10	10	-
16 x 14 x 16	32	1	5 1/4	-	40	1 1/4	7 1/2	-	-	-	-	-	-
16	32	1	5 1/4	-	40	1 1/4	7 1/2	-	40	1 1/2	10	10	-
18 x 16 x 18	32	1 1/8	5 3/4	-	48	1 1/4	7 3/4	-	40	1 5/8	10 3/4	11	-
20 x 16 x 20	40	1 1/8	6 1/4	-	48	1 1/4	8	-	48	1 5/8	11 1/4	11 1/2	-
18	32	1 1/8	6 1/4	-	-	-	-	-	-	-	-	-	-
20*	-	-	-	-	48	1 1/4	7 3/4	-	36	1 5/8	11 1/4	11 1/2	-
	-	-	-	-	-	-	-	-	12	1 5/8	-	-	5 3/4
24 x 20 x 24	-	-	-	-	48	1 1/2	9	-	48	1 7/8	13	13 1/4	-

* Space limitations prevent the use of through bolts in some of the holes in the end flanges on these valves. These holes are drilled and tapped so that a shorter stud bolt or capscrew can be used.

INSTALLATION AND MAINTENANCE - END FLANGE BOLTING DIMENSION

(CONTINUED FROM PREVIOUS PAGE)

ASME/ANSI	CLASS 900				CLASS 1500				CLASS 2500			
Valve Size in.	Number of Fasteners Per Valve	Fastener Diameter in.	Length of Studs RF in.	Length of Studs RTJ in.	Number of Fasteners Per Valve	Fastener Diameter in.	Length of Studs RF in.	Length of Studs RTJ in.	Number of Fasteners Per Valve	Fastener Diameter in.	Length of Studs RF in.	Length of Studs RTJ in.
1	8	3/4	5	5	8	7/8	5	5	-	-	-	-
1 1/2	8	1	5 1/2	5 1/2	8	1	5 1/2	5 1/2	-	-	-	-
2	16	7/8	5 3/4	5 3/4	16	7/8	5 3/4	5 3/4	16	1	7	7
3 x 2 x 3	16	7/8	5 3/4	5 3/4	16	1 1/8	7	7	16	1 1/4	9	9 1/4
3	16	7/8	5 3/4	5 3/4	16	1 1/8	7	7	16	1 1/4	9	9 1/4
4 x 3 x 4	16	1 1/8	6 3/4	6 3/4	16	1 1/4	7 3/4	7 3/4	16	1 1/2	10 1/4	10 3/4
4	16	1 1/8	6 3/4	6 3/4	16	1 1/4	7 3/4	7 3/4	16	1 1/2	10 1/4	10 3/4
6 x 4 x 6	24	1 1/8	7 1/2	7 1/2	24	1 3/8	10 1/4	10 1/2	16	2	13 3/4	14 1/2
6	24	1 1/8	7 1/2	7 1/2	24	1 3/8	10 1/4	10 1/2	16	2	13 3/4	14 1/2
8 x 6 x 8	24	1 3/8	8 3/4	8 3/4	24	1 5/8	11 1/2	12 3/4	24	2	15 1/4	16
8	24	1 3/8	8 3/4	8 3/4	24	1 5/8	11 1/2	12 3/4	24	2	15 1/4	16
10 x 8 x 10	-	-	-	-	24	1 7/8	13 1/4	13 1/2	24	2 1/2	19 1/2	20 1/2
10	32	1 3/8	9 1/4	9 1/4	24	1 7/8	13 1/4	13 1/2	-	-	-	-
12 x 10 x 12	-	-	-	-	32	2	14 3/4	15 1/4	-	-	-	-
12	40	1 3/8	10	10	32	2	14 3/4	15 1/4	-	-	-	-
14 x 12 x 14	40	1 1/2	10 3/4	11	-	-	-	-	-	-	-	-
16 x 12 x 16	-	-	-	-	32	2 1/2	17 1/2	18 1/2	-	-	-	-
16 x 14 x 16	40	1 5/8	11 1/4	11 1/2	-	-	-	-	-	-	-	-

RG/RTJ GROOVE NUMBERS

Size in.	ASME/ANSI Class	Groove Numbers
1	600	R16
1 1/2	600, 900 & 1500	R20
2	600	R23
2	900 & 1500	R24
2	2500	R26
3	600 & 900	R31
3	1500	R35
3	2500	R32
4	600 & 900	R37
4	1500	R39
4	2500	R38
6	600 & 900	R45
6	1500	R46
6	2500	R47
8	600 & 900	R49
8	1500	R50
8	2500	R51
10	600 & 900	R53
10	1500	R54
12	600 & 900	R57
12	1500	R58
14	600	R61
16	600	R65
18	600	R69
20	600	R73

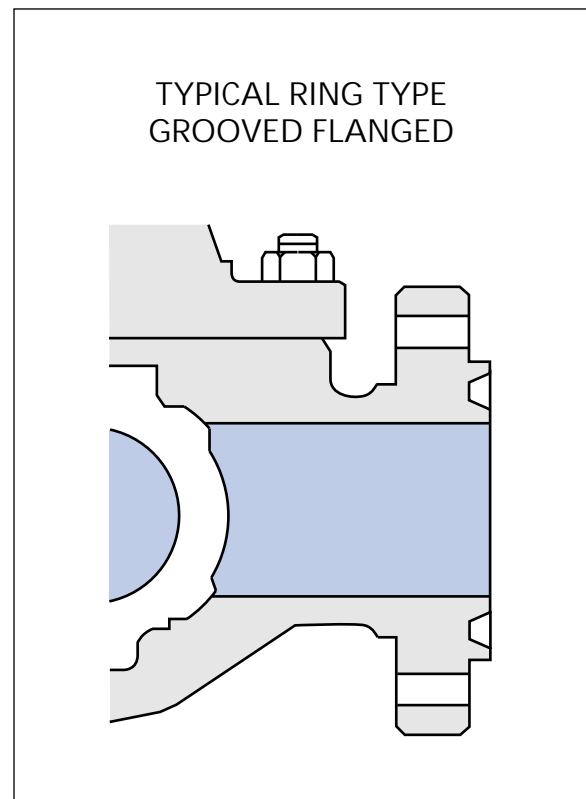

INSTALLATION AND MAINTENANCE

VALVES WITH ONE LUBE POINT



SMALL BORE STANDARD



SMALL BORE O.S.&Y.

VALVES WITH TWO LUBE POINTS



LARGE BORE STANDARD



LARGE BORE O.S.&Y.

*Personal injury and/or damage to property may result. Consult your Orbit Representative for additional information.

INSTALLATION AND MAINTENANCE - LUBRICATION

ORBIT RECOMMENDED LUBRICATION SCHEDULE

The frequency of valve lubrication should be based on user's past experience with installed equipment. The following schedule of lubrication should be used as a minimum guideline until operating experience indicates otherwise:

1. A minimum of once a year.
2. Every time the valve is serviced for stem leak.
3. We recommend quarterly lubrication if valve is operated infrequently (once a day or less).
4. Every 1000 cycles if valve is operated more than 10 times a day.
5. Every 500 cycles if the valve is used in corrosive or other severe services and operated more than 10 times a day.

SPECIAL SERVICE MAINTENANCE

Consult your Orbit Representative before performing any maintenance on valves in special services such as oxygen, ethylene oxide, hydrofluoric acid and any other potentially dangerous services.

RECOMMENDED LUBRICANTS

For standard valves we recommend a high quality lithium base grease. For temperatures below -20°F (-29°C) we recommend a low temperature grease.

The typical fluid used in the gas over oil system is automotive automatic transmission fluid such as Mobil ATF 220 or equivalent.

1 Orbit valves will give maximum performance and long life when used with an effective maintenance program.



4 The only tool required for lubrication is a grease gun with standard hydraulic type coupler. Valves equipped with a lower tube fitting or a grease seal fitting require a safe vent coupler for lubrication. This is available from Orbit or Alemite, part #G-310428.

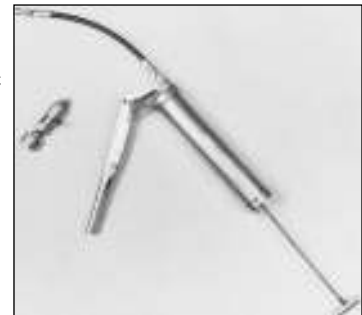

2 Lubrication is not used in Orbit valves to effect a seal. It is used only to reduce friction and wear on moving parts. The only exception is the Grease Seal model which utilizes grease as a secondary sealant.

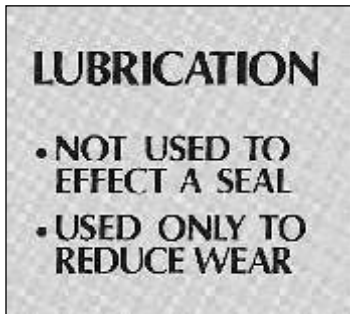

5 **WARNING!** Pressure containing areas of the valve can be dangerous if not handled properly. If valve is in service do not remove any parts unless specifically instructed to do so by an Orbit Representative or Orbit repair manuals.

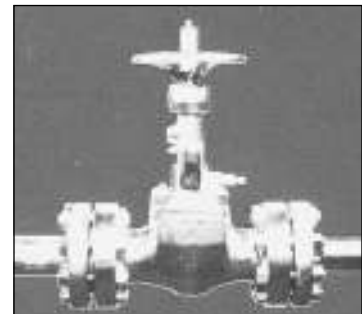

3 The recommended lubrication schedule and types of grease are shown at the top of this page.



6 All Orbit valves are equipped with an upper lube fitting as shown. This lubricates the upper portion of the stem and the bearings. No line pressure will be encountered. Between two and ten strokes on the grease gun provides adequate lube penetration.



INSTALLATION AND MAINTENANCE - LUBRICATION (CONTINUED FROM PREVIOUS PAGE)

7 All large bore Orbit valves are also equipped with a lower lube fitting in the pressure area of the valve. This is a safe vent lube fitting.

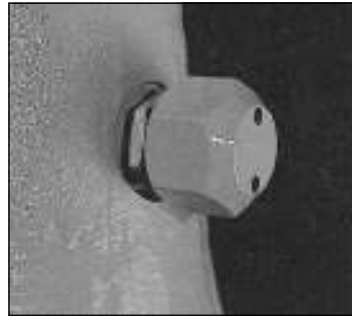

11 Orbit Grease Seal valves are equipped with a safe vent lube fitting in the seat area of the valve.



8 Remove the cap slowly to be sure the ball check in the fitting has sealed off the line pressure. Do not remove any parts other than this cap.



12 Lubrication is identical to steps 8 - 10 except lubricate until the leak stops.

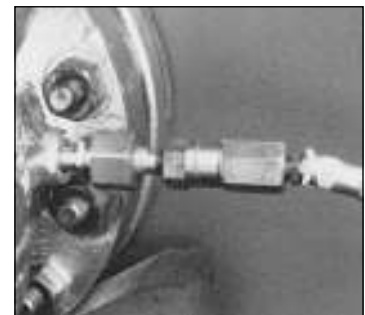

9 Thread the safe vent coupler to the lube fitting. Before attaching the grease gun be sure the output capacity is higher than the line pressure.



13 All Orbit valves (except O.S.&Y. design) equipped with diaphragm actuators are lubricated through the upper lube point on the valve bonnet. No line pressure will be encountered. Two strokes of the grease gun provide adequate lubrication. Excess grease will make the position indicator difficult to see.



10 Two complete strokes on the grease gun provides sufficient lubrication. Cycle the valve if possible to evenly distribute the grease. Excess grease will discharge into the system piping.



14 O.S.&Y. Orbit valves equipped with diaphragm actuators are lubricated at the lube point on the adapter sleeve* above the line pressure. Two strokes of the grease gun provide adequate lubrication. Excess grease will make the position indicator difficult to see.

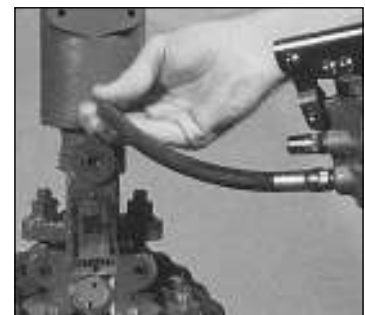

* New style Orbit diaphragm actuators have grease fitting installed in actuator case.

(CONTINUED ON NEXT PAGE)

INSTALLATION AND MAINTENANCE - LUBRICATION (CONTINUED FROM PREVIOUS PAGE)

15 Orbit diaphragm actuators equipped with a manual close mechanism have an additional upper lube point located on the manual closer stem. Spring close diaphragm actuators have no upper lube point.



16 Diaphragm actuators equipped with a two way manual mechanism have an upper lube point that is only accessible when the manual mechanism is in the open position.

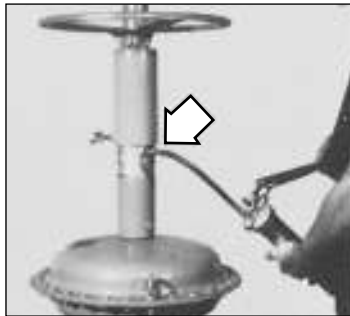

17 All Orbit piston actuators have a lower lube point above pressure line pressure.

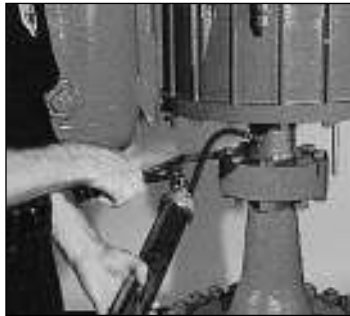

18 Orbit piston actuators equipped with a manual close mechanism have an additional upper lube point, which lubricates the manual mechanism stem. Piston actuators with a two way manual mechanism have no upper lube point.



19 Piston actuators equipped with two way gear mechanism have a lube point on the gear box as shown.

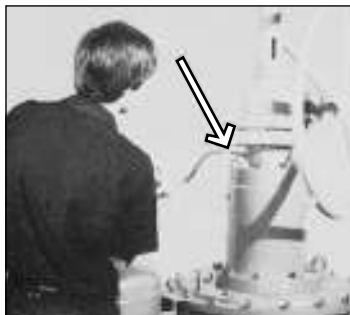

20 All Orbit piston actuators are equipped with a gas over oil tank to assure smooth operation and prevent valve damage. Proper fluid level is important.

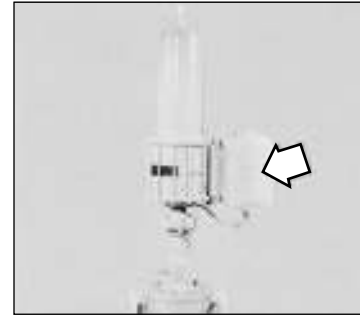

21 To check the fluid level, read the nameplate to determine if the actuator is the LG type or the LS type. If the nameplate is illegible or missing DO NOT attempt to check the fluid level without consulting Orbit Representative.



22 To check fluid level for the LG type, CLOSE the valve. This forces the hydraulic fluid from the actuator into the gas over oil tank. In the closed position the fluid should reach the level indicated in the chart below.

WARNING! If the fill plug is removed in the OPEN position, actuator pneumatic pressure will be encountered if the system is under pressure. Personal injury and/or damage to property may result.

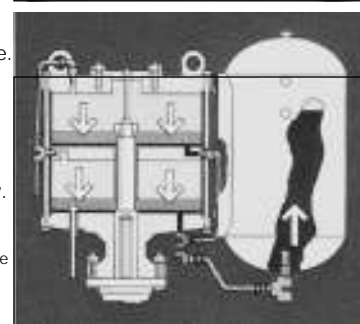

CORRECT FLUID LEVEL FOR LG TYPE PISTON

Actuator	Tank Size		Fluid Level Hole	Capacity	
	in.	mm		gallon	litre
LG-124	12 x 19	305 x 483	one only	5	19
LG-185	14 x 27	356 x 686	bottom	12	45
LG-205, 206	14 x 27	356 x 686	top	15	57
LG-206	14 x 33	356 x 838	top	18	68
LG-266	16 x 38	406 x 965	top	28	106

23 To check the fluid level for the LS type piston actuator, OPEN the valve. This forces the oil from above the lower piston into the gas over oil tank. The fluid should reach the fill plug level indicated in the chart below.

WARNING! If the fill plug is removed in the CLOSED position, actuator pneumatic pressure will be encountered if the system is under pressure. Personal injury and/or damage to property may result.

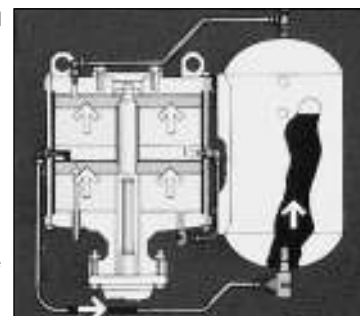

CORRECT FLUID LEVEL FOR LS TYPE PISTON

Actuator	Tank Size		Fluid Level Hole	Capacity	
	in.	mm		gallon	litre
LS-124	10 x 11 1/2	254 x 292	one only	3	11
LS-185	12 x 19	305 x 483	bottom	6	23
LS-205	12 x 19	305 x 483	top	8	30
LS-206	14 x 27	356 x 686	bottom	12	45
LS-266	14 x 27	356 x 686	top	15	57
LS-207	14 x 30	356 x 762	bottom	12	15
LS-208	14 x 30	356 x 762	top	14	53
LS-267	14 x 30	356 x 762	top	14	53
LS-269	16 x 41	406 x 1041	top	25	95

INSTALLATION AND MAINTENANCE - STEM PACKING ADJUSTMENT

1 All Orbit valves except O.S.&Y. bonnet design utilize a hydraulic type stem packing chamber. Stopping stem leaks promptly reduces damage to the packing and the valve.

WARNING! Do not remove packing fitting. Personal injury and/or damage to property may result.

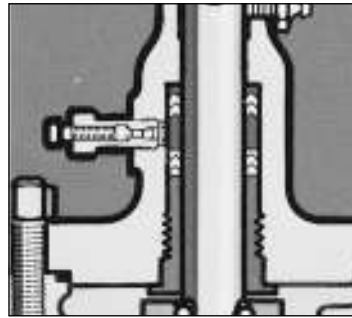

5 Should the plastic packing become depleted, it can be replaced by removing the packing adjustment screw. (This should be done slowly and carefully to be sure the ball check has sealed off the packing chamber pressure.) and replacing it with the type of plastic packing that is shown on the nameplate. Do not substitute without...

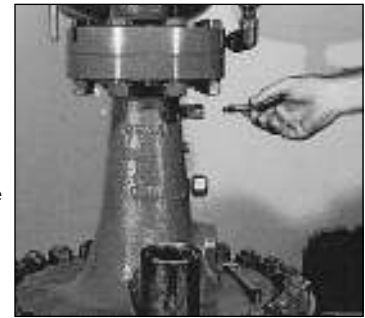

2 Stem leaks are most frequently associated with start ups or other operating changes, but some may develop during steady operation or after long use.

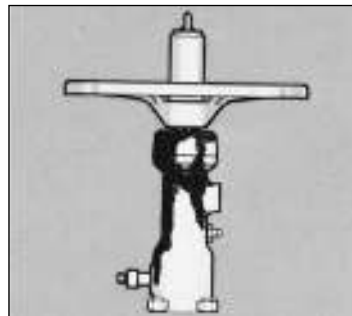

6 ...consulting the chart on page 17. Replace the adjustment screw and advance it to stop the leak but do not exceed a 50 lb. pull on a 6 in. wrench (20 kg pull on a 150 mm wrench). A sufficient number of threads in the packing chamber must be left exposed to allow engagement of the packing screw threads.



3 To stop stem leaks, advance or tighten the packing adjustment screw. This forces the plastic packing past the ball check into the packing chamber.



7 DO NOT OVER PACK! Over packing can result in stiff handwheel operation or can build up excessive pressure in the stem packing chamber, causing forceful expulsion of the entire packing fitting. To prevent over packing when the valve is in service, do not exceed a 50 lb. pull on a 6 in. wrench (20 kgs pull on a 150 mm wrench).



4 As the plastic packing is forced into the packing chamber it increases the pressure and reactivates the Chevron type packing rings. Usually 5 to 10 turns on the adjustment screw will stop the stem leak.

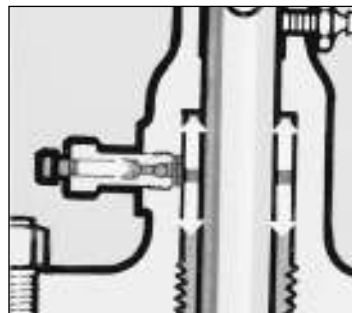

8 If the valve is not in service, partially open the valve and advance the adjustment screw until the handwheel will not coast (freewheel) after being spun. Do not exceed a 50 lb. pull on a 6 in. wrench (20 kg pull on a 150 mm wrench).



(CONTINUED ON NEXT PAGE)

INSTALLATION AND MAINTENANCE - ADJUSTMENT (CONTINUED FROM PREVIOUS PAGE)

9 **WARNING!** If the valve has been over packed - DO NOT TRY TO REMOVE THE BODY OF THE PACKING FITTING to relieve the excessive packing pressure. Injury or damage could result. The packing chamber retains high pressure even if the valve is not in service.

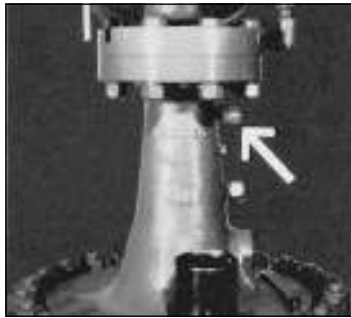

13 If a stem leak occurs, more compression can be applied by evenly adjusting the hex nuts on the gland retainer bolts. Too much compression on the retainer can cause the stem to bind, making the valve hard to operate.

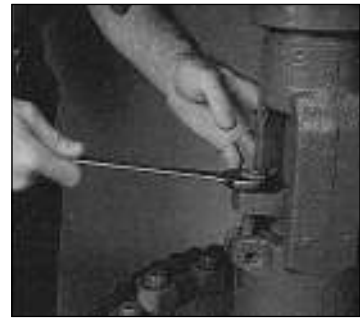

10 Remove the packing adjustment screw and gently tap against the ball check with a 1/8 in. pin punch. This will allow the excessive pressure to escape past the ball check. Wear safety glasses and gloves and stand to the side of the packing fitting centerline while relieving packing pressure.



14 **WARNING!** Never completely remove the hex nuts from the gland retainer bolts while the valve is in service and under pressure. Personal injury and/or damage to property may result.



11 Orbit high temperature valves feature an adjustable type stem packing made possible by utilizing a deep stuffing box, packing gland, and gland flange retained with adjustment bolts and nuts.

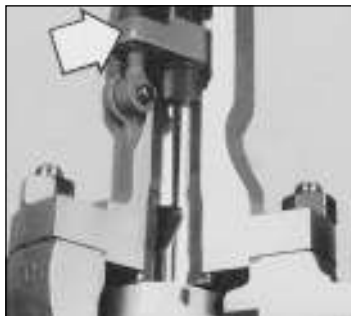

15 For the packing adjustment nuts to be accessible on large bore O.S.&Y. valves the cover must be removed.



12 Effective sealing of pressure by the stem packing rings is maintained by the compression applied to the gland flange and retainer bolts.

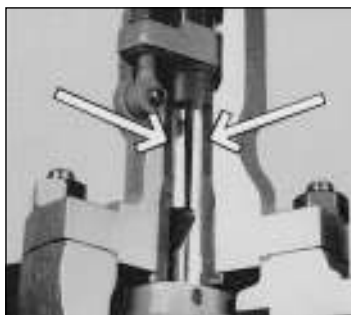

16 The stem packing will not harden up to 800°F (427°C). This packing is very effective, requires little attention, and is suitable for steam, air, water, liquefied petroleum, natural gas and a variety of chemicals.

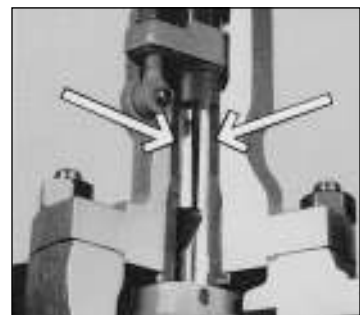

INSTALLATION AND MAINTENANCE STEM PACKING MATERIALS

GP-6

General Service

GP-7

Oxygen and Related Service

GP-19

Ammonia Service

GP-20

High Temperature Graphite Rings O.S.&Y. Model

GP-26

316 S.S. Valve

GP-27

Unleaded Gasoline With MTBE*

RECOMMENDED REPLACEMENT FOR DISCONTINUED PACKING

Obsolete Packing	Recommended Use	Recommended Replacement
GP-5	General Service	GP-6
GP-8	Hydrogen Fluoride Service	GP-19
GP-9	Hydrogen Sulfide Service	GP-6
GP-10	-50°F Service	GP-6
GP-11	Hydril Valve Stem Packing	GP-7
GP-12	Halogen Style	GP-7
GP-14	Chlorine Service	None

Obsolete Packing	Recommended Use	Recommended Replacement
GP-15	HFU Service	GP-19
GP-16	800°F Service (Rings O.S.&Y. Model Only)	GP-20
GP-17	-100°F Service	None
GP-18	600°F Service (Injectable)	None
GP-22	600°F Service (Injectable)	None

*MTBE - Methyl Tertiary Butyl Ether

DRILLING VALVES

1 Orbit Drilling Valves are designed for holding pressure in one direction only. They must be installed so that the greater amount of pressure will be applied to the preferred pressure end. Damage to valve may result if not installed properly.



2 If pressure could drop below 100 psi in the closed position, USE THE STEM LOCKING DEVICE to prevent the valve from opening. To use the Stem Locking Device, tighten the lock screw in the packing gland, which forces a brass friction plug against the valve stem.



3 The special lube fitting on top of the valve is in the valve pressure area so use these precautions:

- A Attach a grease gun with out-put higher than line pressure to the fitting.
- B Back out the shut-off-screw 2 to 3 turns ONLY.
- C Pump in 1 to 2 lbs., 0.5 to 1 kg., of lithium base grease, and if possible cycle the valve to evenly distribute the lubricant.
- D Tighten the shut-off screw securely before removing the pump. The stem lube point "A" use a standard hydraulic lube fitting. Pump two or three times.

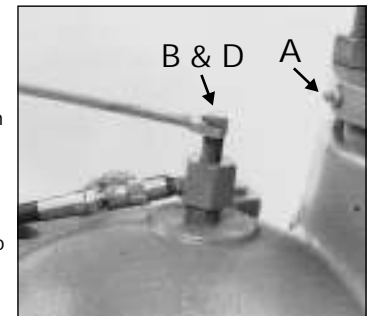

4 The conventional type Packing Gland Assembly uses braided packing rings and gland studs with nuts. Adjustment is identical to O.S.&Y. valves shown on page 16, steps 11 to 15.



TRADEMARK INFORMATION

Orbit® is a registered trademark which is owned by Cameron.

This document contains references to registered trademarks or product designations, which are not owned by Cameron.

Trademark	Owner
Carpenter 450	Carpenter Technology Corp.
Hastelloy	Haynes International, Inc.
Inconel	Special Metals Corp.
Latrobe	Timkin Latrobe Steel
Monel	Special Metals Corp.
PEEK	Victrex PLC.
Stellite	Deloro Stellite, Inc.
Teflon	DuPont
Ultimet	Haynes International, Inc.
Viton	DuPont

CAMERON, VALVES & MEASUREMENT TERMS AND CONDITIONS OF SALE

1. CONTRACT ACCEPTANCE:

Any written or oral purchase order received from Buyer by Seller shall be construed as a written acceptance of Seller's offer to sell and shall be filled in accordance with the terms and conditions of sale set forth herein. SELLER'S ACCEPTANCE OF THIS ORDER IS EXPRESSLY CONDITIONED ON BUYER'S ASSENT TO THE TERMS CONTAINED HEREIN. The terms and conditions of Seller's proposal (if any) and acknowledgement shall prevail over any conflicting or different terms in Buyer's order unless Buyer notifies Seller in writing of its objections thereto within fifteen (15) days from receipt of Seller's acknowledgement. Buyer's standard terms of purchase will not be considered a counteroffer to Seller's terms and conditions of sale. The failure of Seller to object to any provision in conflict herewith whether contained on Buyer's purchase order or otherwise shall not be construed as a waiver of the provisions hereof nor as an acceptance thereof.

2. QUOTATIONS AND PRICES:

Any product, service capability or manufacturing capability which may be available at the time a quotation is made is subject to prior sale. Prices quoted are subject to change without notice. The price in effect at the time of shipment including any escalation formula will apply, unless a valid quotation or written agreement to the contrary exists between Buyer and Seller. All prices shown are in U.S. dollars and are F.O.B. Seller's shipping point. Seller reserves the right to place a service charge on past due accounts at the highest rate permitted by law. Any documentation pertaining to traceability requirements for raw materials or products or documentation required for any routine or special processes must be identified by the Buyer at the time of quotation (if any) or at the time of order placement.

3. TAXES:

Any tax or other charge imposed by law on the sale or production of goods or the performance of services shall be paid by the Buyer, unless the law specifically provides that such payment must be made by Seller, in which case Buyer shall reimburse Seller for such payment as part of the purchase price. Custom duties, consular fees, insurance charges and other comparable charges will be borne by Buyer.

4. SHIPPING SCHEDULE AND DELIVERY:

Shipment schedules are given as accurately as conditions permit and every effort will be made to make shipments as scheduled. Seller will not be responsible for deviations in meeting shipping schedules nor for any losses or damages to Buyer (or any third party) occasioned by deviations in the shipping schedule, whether due to Acts of God, orders bearing priority ratings established pursuant to law, differences with workmen, local labor shortages, fire, flood, shortages or failure of raw materials, supplies, fuel, power or transportation, breakdown of equipment or any other causes beyond Seller's reasonable control, whether of similar or dissimilar nature than those enumerated. Seller shall have additional time within which to perform as may be reasonably necessary under the circumstances and shall have the right to apportion its production among its customers in such a manner as it may consider to be equitable. Seller reserves the right to furnish commercially equivalent or better substitutes for materials or to subcontract the Buyer's order or portions thereof as Seller deems necessary. In no event shall Seller be liable for any consequential damages resulting from failure or delay in shipment. If Buyer requires drawings, procedures, standards or similar material for approval, shipping schedules will be calculated from the time such approvals are received by Seller, since shipping schedules are based on Seller having all required information and a firm order from Buyer which is enterable into production. Any hold points, witness points or the need for inspection by Buyer's representatives must be identified by Buyer at the time of quotation (if any) and/or order placement in order that the effect on the prices or shipping schedules (if any) can be taken into account. Additional inspection or testing required by Buyer which affects normal production sequence will be considered as extending the shipping dates accordingly.

5. TERMS OF PAYMENT:

Terms of payment are 30 days from date of invoice unless otherwise stated in the quotation or Seller's order acknowledgment.

6. CANCELLATIONS AND RETURNS:

Purchase orders once placed by Buyer and accepted by Seller can be canceled only with Seller's written consent and upon terms which will save Seller from loss. No products may be returned for credit or adjustment without written permission from Seller's office authorized to issue such permission.

7. WARRANTIES:

All products of Seller's manufacture except for its Orbit product are warranted against defects of material and workmanship for a period of twelve (12) months from the date of installation or eighteen (18) months from date of shipment, whichever period first expires while its Orbit product is warranted for thirty six (36) months from date of shipment, when all such products are used in the service and within the pressure range for which they were manufactured. In the case of products or parts not wholly of Seller's manufacture, Seller's liability shall be limited to the extent of its recovery from the manufacturer of such products or parts under its liability to Seller. Any repair work performed by Seller is warranted for one year from completion of such repairs and applies only to work performed. If, within these specified periods, Seller receives notice from Buyer of any alleged defect in or nonconformance of any product or repair and if in the Seller's sole judgment the product or repair does not conform or is found to be defective in material or workmanship, then, Buyer shall, at Seller's request, return the part or product F.O.B. to Seller's designated plant or service location. Seller has no liability for removal or reinstallation of products or equipment. Seller, at its option and expense, shall repair or replace the defective part or product, or repay to Buyer the full price paid by Buyer for such defective part, repair or product. Any repayment of purchase price shall be without interest. Seller's warranty liability, including defects caused by Seller's negligence, shall be limited to such repair, replacement or refund, and shall not include claims for labor costs, expenses of Buyer resulting from such defects, recovery under general tort law or strict liability or for damages resulting from delays, loss of use, or other direct, indirect, incidental or consequential damages of any kind. Seller will not be responsible for failures of products which have been in any way tampered with or altered by anyone other than an authorized representative of Seller, failures due to lack of compliance with recommended maintenance procedures or products which have been repaired or altered in such a way (in Seller's judgment) as to affect the products adversely. THIS WARRANTY IS EXPRESSLY IN LIEU OF ALL OTHER WARRANTIES, EXPRESS, STATUTORY OR IMPLIED, INCLUDING THE WARRANTY OF MERCHANTABILITY AND FITNESS FOR PARTICULAR PURPOSE WHICH EXCEED THE FOREGOING WARRANTY.

8. ENGINEERING AND SERVICE:

Upon request, Seller will provide engineering and/or technical information regarding its products and their uses and, if feasible, will provide personnel to assist Buyer in effecting field installations and/or field service. Any such information, service or assistance so provided, whether with or without charge, shall be advisory only.

9. LABOR STANDARDS:

Seller hereby certifies that these products were produced in accordance with all applicable requirements of Section 6, 7 and 12 of the Fair Labor Standards Act as amended and of regulations and orders of the United States Department of Labor issued under Section 14 thereof.

10. INSPECTION:

Unless otherwise agreed in writing, final inspection and acceptance of products must be made at Seller's plant or other shipping or receiving point designated by Seller and shall be conclusive except as regards latent defects. Buyer's representatives may inspect at the Seller's plant or shipping point during working hours prior to shipment in such manner as will not interfere with operations.

11. DELIVERY AND ACCEPTANCE:

Delivery shall be in accordance with the requirements in the Purchase Contract, provided, in the event Buyer is unable to accept delivery upon completion of the manufacture of the Goods in accordance with such requirements, Buyer agrees that (i) title and risk of ownership shall pass to Buyer on date of Seller's invoice, and (ii) Buyer will make payments within thirty days after date of such invoice. Seller shall retain custodial risk of loss until delivery is made in accordance with such requirements.

12. EXPORT COMPLIANCE:

The Buyer shall provide the Seller with relevant end-use, end-user and country of end-use information with respect to the goods, services, software or technology to be supplied hereunder (collectively, "Items"). Based on and in reliance on such information, the Seller will supply such Items in compliance with applicable trade and customs laws including that of the United States of America. The Seller cautions and the Buyer acknowledges that any change in end-use, end-user or country of end-use (including a shipment between countries other than the U.S.) may be restricted or prohibited by applicable trade and

customs law, whether it be of the U.S. or other country. The Parties shall comply with all trade and customs laws (including U.S. Export Controls) except for any such laws which conflict with or are otherwise penalized under the laws of the U.S., which in the event of such conflict, Seller shall notify Buyer. The Buyer agrees in particular that it shall not use and shall not permit any third party to use such items in connection with the design, production, use, or storage of chemical, biological or nuclear weapons or missiles of any kind.

13. TRANSPORTATION CHARGES, ALLOWANCES, CLAIMS:

All prices are F.O.B. Seller's plant or other designated shipping point. No freight is allowed unless stated in Seller's quotation (if any) or in a written contract which may exist between Seller and Buyer at the time of shipment. If Seller's quotation or a written contract states that all or a portion of freight is allowed, all prices are F.O.B. Seller's plant or other designated shipping point, with most economical surface transportation allowed. If the quoted or contractual price includes transportation, Seller reserves the right to designate the common carrier and to ship in the manner it deems most economical. Added costs due to special routing requested by the Buyer are chargeable to the Buyer. Under no circumstances is any freight allowance which is absorbed by Seller to be deducted from the selling price. If the quoted price or contract includes transportation, no deduction will be made in lieu thereof whether Buyer accepts shipment at plant, warehouse, freight station, or otherwise supplies its own transportation. When sales are made from the Seller's warehouse, Seller reserves the right to charge either actual or pro-rated freight from Seller's principle point of manufacture to Seller's warehouse. Buyer assumes risk of loss upon delivery to the carrier, regardless of who pays shipping costs. Seller endeavors to pack or prepare all shipments so that they will not break, rust or deteriorate in transit, but does not guarantee against such damage. Unless requested in writing by the Buyer, no shipments are insured by Seller against damage or loss in transit. Seller will place insurance as nearly as possible in accordance with Buyer's written instructions but in such case Seller acts only as agent between the insurance company and the Buyer and assumes no liability whatsoever. Any claims for shipping loss, breakage or damage (obvious or concealed) are Buyer's responsibility and should be made to the carrier. All claims regarding shortages must be made within thirty (30) days from receipt of shipment and must be accompanied by the packing list(s) covering the shipment.

14. INDEMNIFICATION AND LIMITATION OF LIABILITY:

A. INDEMNIFICATION:

"Buyer Group" means: Buyer, its parent (if any), subsidiaries, affiliates, co-owners, co-venturers, partners and any entity with whom Buyer has an economic interest with respect to the Work including Buyer's customer and its and their respective employees, personnel, directors, officers, borrowed servants, representatives, agents, contractors and subcontractors (respectively and of any tier or level and who are not included within the Seller Group), "Seller Group" means: Seller, its parent (if any), subsidiaries, affiliates, co-owners and its and their respective employees, personnel, directors, officers, borrowed servants, representatives, agents, contractors and subcontractors (respectively and of any tier or level and who are not included within the Buyer Group), "Negligence" means: sole, joint or concurrent, active, passive, gross or willful misconduct.

(1) Seller shall release, defend, save, indemnify (collectively "Indemnify") and hold Buyer Group harmless from and against all claims, demands, losses, damages and causes of action of whatever kind or nature (collectively "Claims"), for loss of or damage to the property of the members of the Seller Group even if such Claims arise from or attributable to the Negligence of the members of Buyer Group.

(2) Seller shall Indemnify and hold Buyer Group harmless from and against all Claims for the death(s) of or personal injury(ies) to members of the Seller Group even if such Claims arise from or attributable to the Negligence of the members of Buyer Group.

(3) Buyer shall Indemnify and hold Seller Group harmless from and against all Claims for loss of or damage to the property (including the Work) of the members of the Buyer Group even if such Claims arise from or attributable to the Negligence of the members of Seller Group.

(4) Buyer shall Indemnify and hold Seller Group harmless from and against all Claims for the death(s) of or personal injury(ies) to members of the Buyer Group even if such Claims arise from or attributable to the Negligence of the members of Seller Group.

(5) Buyer (on its own behalf and on behalf of Buyer Group) and Seller (on its own behalf and on behalf of Seller Group) shall Indemnify and hold each other harmless from and against any and all Claims asserted against them by or on behalf of any third party for the death(s) of or personal injury (ies) to such a third party, as well as loss (es) of or damage(s) to the property of such a third party. A third party is a person or entity not included in Buyer Group or Seller Group. It is agreed by Buyer and Seller that their respective duty of indemnity to each other with respect to Claims asserted against them by a third party pursuant to this Article 14 (A) (5) shall be limited to their respective degree of Negligence.

(6) Notwithstanding any other provision contained in this Agreement, Buyer shall Indemnify and hold the members of Seller Group harmless from and against all Claims (including clean-up costs and loss (es) of oil, gas or hydrocarbons) arising from pollution, contamination, dumping or spilling of any substance and even if arising out of or attributable to the Negligence of the members of the Seller Group.

B. INDEMNITY FOR CONSEQUENTIAL DAMAGES:

UNDER NO CIRCUMSTANCES SHALL SELLER BE LIABLE FOR ANY SPECIAL, CONSEQUENTIAL, INCIDENTAL, EXEMPLARY OR PUNITIVE DAMAGES (collectively "CONSEQUENTIAL"). AS DEFINED BY THE LAWS GOVERNING THIS PURCHASE ORDER, NOR FOR ANY LOSS OF ANTICIPATED PROFITS, LOSS OF BUSINESS OPPORTUNITY, LOSS OF USE OF EQUIPMENT OR OF ANY INSTALLATION, SYSTEM OR FACILITY INTO WHICH SELLER'S EQUIPMENT MAY BE LOCATED OR AT WHICH MEMBERS OF THE SELLER GROUP MAY BE PERFORMING WORK AND BUYER AGREES TO "INDEMNIFY" AND HOLD SELLER GROUP HARMLESS FROM AND AGAINST ANY "CLAIMS" FOR SUCH "CONSEQUENTIAL" DAMAGES EVEN IF ARISING OUT OF OR ATTRIBUTABLE TO THE "NEGLIGENCE" OF THE MEMBERS OF THE SELLER GROUP.

C. LIMITATION OF LIABILITY:

EXCEPT AS OTHERWISE EXPRESSLY LIMITED IN THIS AGREEMENT IT IS THE EXPRESS INTENTION OF THE PARTIES HERETO THAT ALL INDEMNITY OBLIGATIONS AND/OR LIABILITIES HEREBY ASSUMED BY THE PARTIES SHALL BE: (i) SUPPORTED BY INSURANCE; (ii) WITHOUT LIMIT; (iii) AND WITHOUT REGARD TO THE CAUSE OR CAUSES THEREOF, INCLUDING, BUT NOT LIMITED TO, PREEXISTING CONDITIONS (WHETHER SUCH CONDITIONS BE PATENT OR LATENT); THE UNSEAWORTHINESS OF ANY VESSEL OR VESSELS (WHETHER OR NOT PREEXISTING); THE UNAIRWORTHINESS OF ANY AIRCRAFT; BREACH OF REPRESENTATION OR WARRANTY (EXPRESS OR IMPLIED); BREACH OF CONTRACT; BREACH OF DUTY (STATUTORY, CONTRACTUAL, COMMON LAW OR OTHERWISE); STRICT LIABILITY; CONDITION OF RUIN OR DEFECTIVE PREMISES, EQUIPMENT, FACILITIES, OR APPURTENANCES OF ANY PARTY UNDER ANY CODE, LAW OR (WHETHER OR NOT SAID CONDITION IS PREEXISTING AND/OR LATENT, PATENT OR OTHERWISE); THE LOADING OR UNLOADING OF PERSONS OR CARGO; TORT; OR THE NEGLIGENCE OR FAULT OF ANY PARTY (AS DEFINED AT THE BEGINNING OF THIS ARTICLE 14; OR ANY OTHER THEORY OF LEGAL LIABILITY).

Seller's total responsibility for any claims, damages, losses or liability arising out of or related to its performance of this contract or the products or services covered hereunder shall not exceed the purchase price.

15. MODIFICATION, RESCISSION & WAIVER:

The terms herein may not be modified or rescinded nor any of its provisions waived unless such modification, rescission or waiver is in writing and signed by an authorized employee of Seller at its office in Houston, Texas. Failure of Seller to insist in any one or more instances upon the performance of any of the terms and conditions of the contract or the failure of Seller to exercise any of its rights hereunder shall not be construed as a waiver or relinquishment of any such term, condition, or right hereunder and shall not affect Seller's right to insist upon strict performance and compliance with regard to any unexecuted portions of this contract or future performance of these terms and conditions.

All orders must be accepted by an authorized employee of Seller. The rights and duties of the parties and construction and effect of all provisions hereof shall be governed by and construed according to the internal laws of the State of Texas. Any disputes which arise under this agreement shall be venued in the District Court of Harris County, Texas or in the Southern District of Texas.

**VALVES & MEASUREMENT**

3250 Briarpark Drive, Suite 300
Houston, Texas 77042
USA Toll Free 800 323 9160

For the most current contact and location information go to: www.c-a-m.com